

HYDROBRONPI-70E

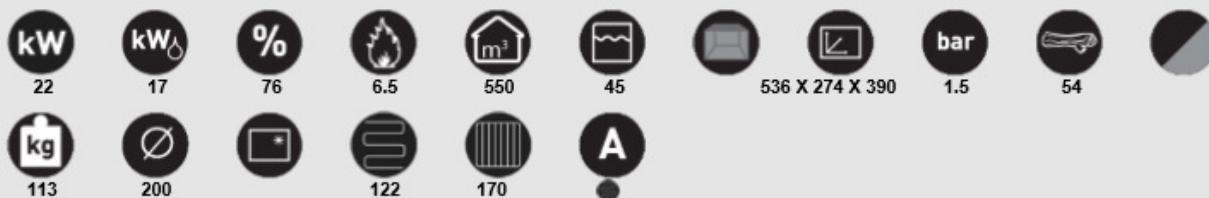

Features

- Heating power: 22kw
- Power transferred to water (kW): 17kw
- Efficiency (%): 76%
- Consumption (kg/h): 6,5kg/h
- Heating capacity (m3): 550m3
- Tank capacity (l): 45l
- Metallic interior
- Manufactured in cast-iron and sheet
- Weight (kg): 113kg
- Smoke exit tube diameter (mm): 200mm
- Clean glass system
- Useful oven measures: 536 X 274 X 390mm
- Working pressure (bar): 1.5bar
- Maximum logs size (cm): 54cm
- Underfloor heating (m2): 170
- N° radiator elements: 122
- Compatible accesories not included: F-503; KIT-1; KIT-2; VAL-01; VAL-02

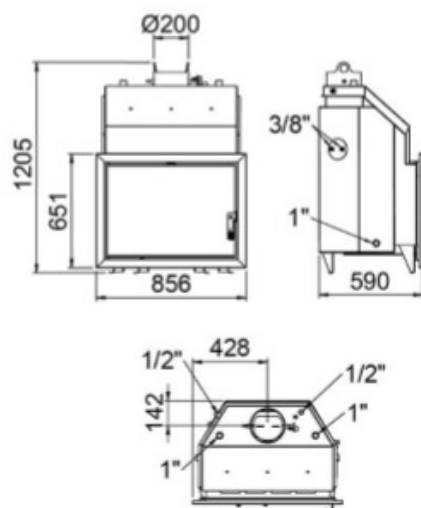

HYDROBRONPI-80E VISION

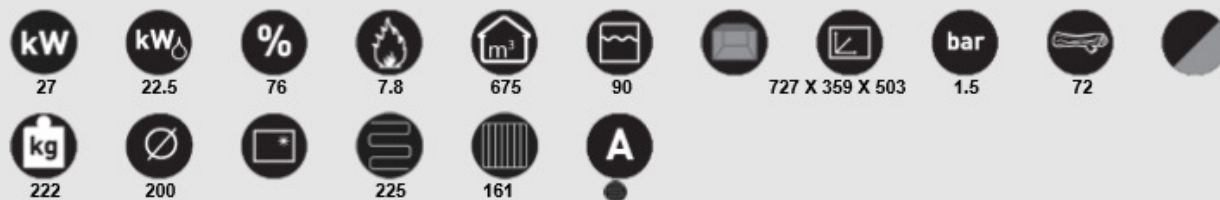

Features

- Heating power: 27kw
- Power transferred to water (kW): 22.5kw
- Efficiency (%): 76%
- Consumption (kg/h): 7.8kg/h
- Heating capacity (m3): 675m3
- Tank capacity (l): 90l
- Metallic interior
- Manufactured in cast-iron and sheet
- Weight (kg): 222kg
- Smoke exit tube diameter (mm): 200mm
- Clean glass system
- Useful oven measures: 727 X 359 X 503mm
- Working pressure (bar): 1.5bar
- Maximum logs size (cm): 72cm
- Underfloor heating (m2): 225
- N° radiator elements: 161
- Compatible accesories not included: F-503; KIT-1; KIT-2; VAL-1; VAL-3

